



Operating Instructions

Models 36200, 362000, 46200, 462000

Hydrostatic Test Pumps

Specifications

46200 DIMENSIONS:	28" (70cm) L x 24" (60cm) W x 38" (87.5cm) H
WEIGHT:	89 lbs. , 41 kg gross
PUMP:	Triplex Piston: Positive Displacement Inlet and Outlet Ports: 3/8" NPT Capacity: 3.5gpm, 13lpm Pressure: 0 – 1200psi (82 bar) Max Temp: 160 degree F Lubrication: Continuous oil bath 11.83 oz Special Cat Pump Oil
ENGINE:	6.5hp Briggs & Stratton Intek Pro, 4 cycle gasoline, with 6-1 gear reduction
CONTROL:	Adjustable Pressure Relief Valve
GAUGE:	Glycerin filled, 0 –2000psi (136 bar)
DISCHARGE HOSE:	½ " x 10' (3m), 2000psi
INTAKE HOSE:	¾" x 10' (3m) with strainer
462000 DIMENSIONS:	28" (70cm) L x 24" (60cm) W x 38" (87.5cm) H
WEIGHT:	89 lbs. , 41 kg gross
PUMP:	Triplex Piston: Positive Displacement Inlet and Outlet Ports: 3/8" NPT Capacity: 3.5gpm, 13lpm Pressure: 0 – 1200psi (82 bar) Max Temp: 160 degree F Lubrication: Continuous oil bath 11.83 oz Special Cat Pump Oil
ENGINE:	5.5hp Honda engine, gasoline
CONTROL:	Adjustable Pressure Relief Valve
GAUGE:	Glycerin filled, 0 –2000psi (136 bar)
DISCHARGE HOSE:	½ " x 10' (3m), 2000psi
INTAKE HOSE:	¾" x 10' (3m) with strainer
36200 DIMENSIONS:	25" (63cm) L x 20" (50cm) W x 21" (53cm) H
WEIGHT:	87 lbs. , 40 kg gross
PUMP:	Triplex Piston: Positive Displacement Inlet and Outlet Ports: 3/8" NPT Capacity: 3.5gpm, 13lpm Pressure: 0 – 1200psi (82 bar) Max Temp: 160 degree F Lubrication: Continuous oil bath 11.83 oz Special Cat Pump Oil
ENGINE:	6.5hp Briggs & Stratton Intek Pro, 4 cycle gasoline, with 6-1 gear reduction
CONTROL:	Adjustable Pressure Relief Valve
GAUGE:	Glycerin filled, 0 –2000psi (136 bar)
DISCHARGE HOSE:	½ " x 10' (3m), 2000psi
INTAKE HOSE:	¾" x 10' (3m) with strainer
362000 DIMENSIONS:	25" (63cm) L x 20" (50cm) W x 21" (53cm) H
WEIGHT:	87 lbs. , 40 kg gross
PUMP:	Triplex Piston: Positive Displacement Inlet and Outlet Ports: 3/8" NPT Capacity: 3.5gpm, 13lpm Pressure: 0 – 1200psi (82 bar) Max Temp: 160 degree F Lubrication: Continuous oil bath 11.83 oz Special Cat Pump Oil
ENGINE:	5.5hp Honda engine, gasoline
CONTROL:	Adjustable Pressure Relief Valve
GAUGE:	Glycerin filled, 0 –2000psi (136 bar)
DISCHARGE HOSE:	½ " x 10' (3m), 2000psi
INTAKE HOSE:	¾" x 10' (3m) with strainer





Operating Instructions

Models 36200, 362000, 46200, 462000

Hydrostatic Test Pumps

Pressure Feed (or Gravity Feed) Method: (Preferred Methods)

1. Fill the water line (or test vessel) to be tested prior to pump connection.
2. Connect water supply hose to the garden hose inlet (F) connection on the pump.
3. Open valve and turn supply water on.
4. Purge the pump and pressure hose of all air.
5. Connect output (pressure) hose between pump (I) and water line (or vessel) being tested. (Water line or test vessel should be pre-filled with water before the test pump is attached.)
6. Turn pump on.
7. Purge water line (or vessel) of all air at the highest point of the system.
8. Bring water line (or vessel) to pressure. Watch the gauge (A) while pumping. When the desired pressure is achieved, turn the isolation valve (H) to the "off" position. The engine can now be turned off. If pressure drops, there is a leak in the line.

Siphon Method

Use a clean water source

1. Fill the water line to be tested.
2. Fill the intake hose (WR PN #34550 - not supplied with pump), with water, then quickly place the hose into a bucket and turn pump on. (The unit is self-priming once primed.) Continue to pump until you see the water coming out of the outlet, with little or no air mixed with it.
3. Connect the output hose to the water line. Continue on with steps 6 through 8 in pressure feed method.

Pre-Setting Your Pump

Your pump can be pre-set to a specific pressure easily by adjusting the pressure relief valve.

1. Loosen the jam nut (C), then unscrew (counterclockwise direction) the pressure relief valve knob (B) a few turns. (Test pump comes pre-set at 1200psi). Be sure not to unscrew the relief valve all the way. Parts can be easily lost.
2. Add a ball valve (not supplied with pump) to the end of the high pressure hose.
3. Follow steps 2 through 4 from the 'Pressure Feed Method'.
4. As water is flowing out of the high pressure hose, turn the ball valve to the off position.
5. Slowly start turning pressure relief valve (B) (in the clockwise direction) by $\frac{1}{4}$ turn increments, until you reach the desired pressure. Tighten the jam nut (C) when finished.
6. Your test pump is now pre-set. This eliminates over-pressurizing the water line (or the vessel).



Operating Instructions

Models 36200, 362000, 46200, 462000

Hydrostatic Test Pumps

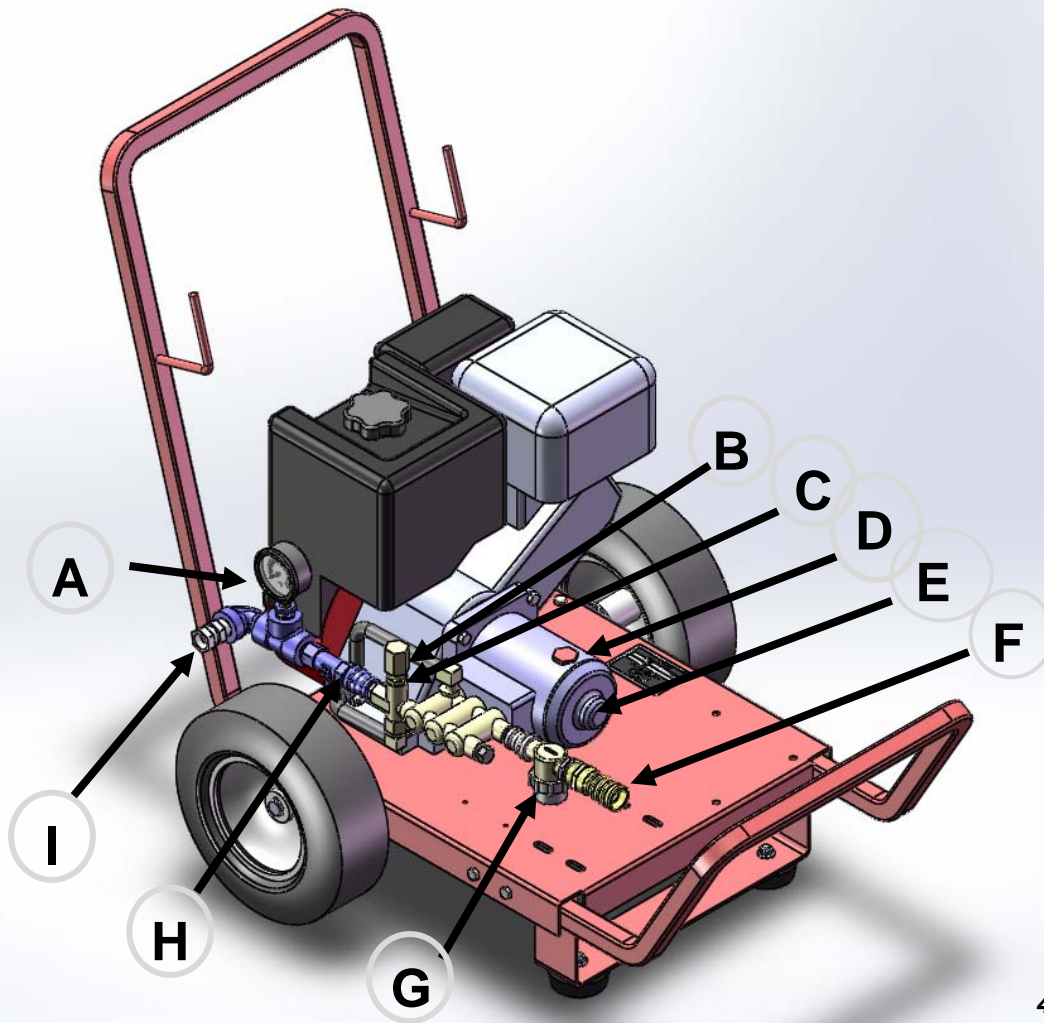

46200 Shown

A	Gauge
B	Pressure Relief Valve
C	Jam Nut
D	Oil Cap
E	Oil Sight Glass
F	Water Inlet Connection
G	Strainer
H	Isolation Valve
I	High Pressure Hose Connection



Operating Instructions

Models 36200, 362000, 46200, 462000

Hydrostatic Test Pumps

Troubleshooting Your Pump

Test pressure not being reached:

- Possible air in line (or vessel)
 - ◊ Air needs to be purged from system.
 - ◊ Remove pump from system and follow steps 1 thru 6 of the "Pre-Setting Your Pump" section.
 - ◊ If using the Siphon Method and not getting pressure, try the 'Pressure Feed' or 'Gravity Feed Method' to ensure water is getting into the pump.
 - ◊ Check strainer O-Ring for cracks (G).
- Pressure relief valve not adjusted properly.
 - ◊ Turn relief valve counterclockwise and watch for change in pressure.

Pump Maintenance

- Pump 50/50 antifreeze/water solution through pump after each use to lubricate internal parts of pump and to avoid freezing in cold weather.
- Check strainer O-Ring (G) for cracks prior to each use.
- Check and change engine oil per manufacturer's specs
- CAT Pump Crankcase Oil (21oz container), WR PN 276254 needs to be used. Add oil thru oil cap (D). Fill to pump specs. See oil level sight glass (E)
- Pump seal kit Wheeler Rex PN 34053
- Discharge Valve Kit Wheeler Rex PN 34052
- Suction Hose Wheeler Rex PN 34550

CAUTION !!!

This pump is designed for water only!!

The pump is equipped with an adjustable pressure relief valve (B), which helps protect the system from being over pressurized. It can be preset by plugging the end of the hose. Turn the adjusting knob clockwise to increase pressure and counterclockwise to decrease.



WHEELER-REX LIMITED LIFETIME WARRANTY

WHEELER-REX covers its products with a Limited Lifetime Warranty, with exception of pipe threading machines which have a Limited Three Year Warranty (including electric motors). Warranties from manufacturers of components used in our products may pre-empt the Wheeler-Rex warranty. Wheeler-Rex warranties against defects in material or workmanship. To take advantage of this warranty, the complete product must be delivered prepaid to Wheeler-Rex or any WHEELER-REX AUTHORIZED SERVICE CENTER. No tools are to be returned to the factory without receiving prior authorization. Obviously, failures due to misuse, abuse, or normal wear and tear are not covered by this warranty. **NO OTHER WARRANTY, WRITTEN, OR ORAL, APPLIES. THERE ARE NO WARRANTIES WHICH EXTEND BEYOND THE DESCRIPTION ON THE FACE HEREOF.** No employee, agent, dealer, or other person is authorized to give any warranty on behalf of Wheeler-Rex. Warranted products will be repaired or replaced at our option, at no charge and returned to you via prepaid transportation. Such replacement or repair is the exclusive remedy available from Wheeler-Rex. Wheeler-Rex is not liable for damage of any sort, including incidental and consequential damages. Some U.S.A. states do not allow the exclusion or limitation of incidental or consequential damages, so the above limitation or exclusion may not apply. This warranty gives you specific legal rights, and you may also have other rights which vary from state to state.

Form # 1031

WARNING

GENERAL TOOL OPERATION WARNINGS

FOR ALL TOOLS-

1. **Keep Guards in Place** and in working order.
2. **Remove Adjusting Keys and Wrenches** from tool before turning it on.
3. **Keep Work Area Clean.** Cluttered areas and benches invite accidents.
4. **Avoid Dangerous Environment.** Don't use power tools in damp or wet locations. Keep work area well lit. Don't expose power tools to rain.
5. **If you must use an electric tool in a damp or wet location;** make sure it is plugged into a circuit which is protected by a ground fault interrupt.
6. **Keep Children Away. ALL VISITORS SHOULD BE KEPT A SAFE DISTANCE FROM WORK AREA.**
7. **Store Idle Tools** in dry, high, or locked-up place out of reach of children.
8. **Don't Force Tool.** It will do a better and safer job at the rate for which it is designed.
9. **Use Right Tool.** Don't force a small tool or attachment to do the job of a heavy-duty tool.
10. **Wear Proper Apparel.** No loose clothing or jewelry to get caught in moving parts. Rubber gloves and footwear are recommended when working outdoors.
11. **Use Safety Glasses.**
12. **Don't Abuse Cord.** Never carry tool by cord or yank it to disconnect from receptacle. Keep cord from heat, oil, and sharp edges.
13. **Secure Work.** Use clamps or vise to hold work when practical. It's safer than using your hand and it frees both hands to operate tool.
14. **Don't Overreach.** Keep proper footing and balance at all times.
15. **Maintain Tools Properly.** Keep tools sharp and clean for best and safest performance. Follow instructions for lubricating and changing accessories. Equipment operators must have proper maintenance & instruction sheets. Be sure the tool operator reads and understands this information. If you don't have current maintenance and instruction sheets, contact the factory & we will supply them at no charge.
16. **Disconnect Tools** when not in use; before servicing; when changing accessories such as dies, cutters, etc.
17. **Avoid Accidental Starting.** Don't carry plugged-in tool with finger on switch. Be sure switch is off when plugging in.
18. **Outdoor Use Extension Cords.** When tool is used outdoors, use only extension cords suitable for use outdoors and so marked.
19. **Wear Ear Protection** if exposed to long periods of very noisy shop operations.
20. **Do not operate tools** while under the influence of alcohol, drugs or medication.

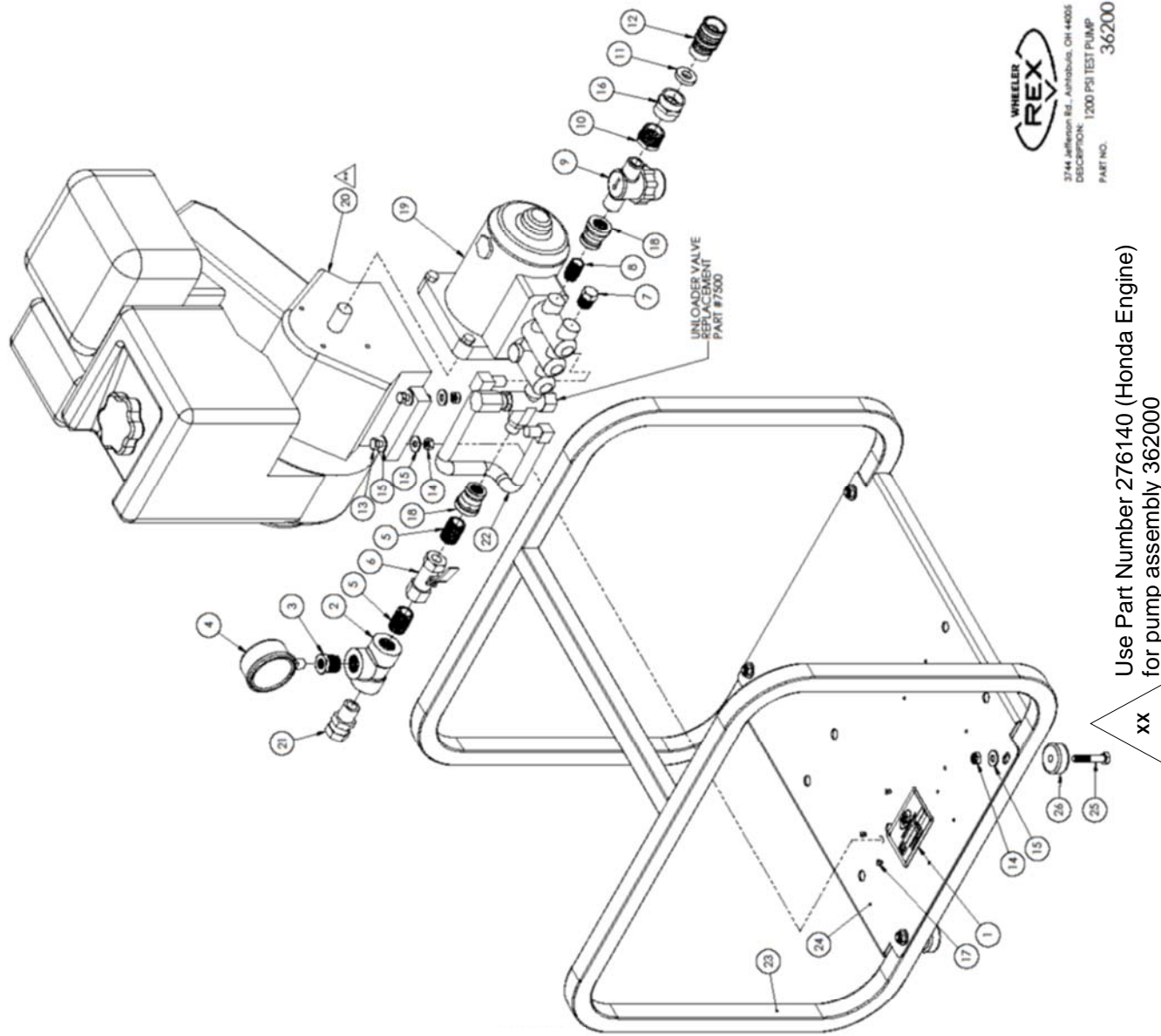



 274 Jefferson Rd., Aurora, OH 44005
 DESCRIPTION: 1200 PSI TEST PUMP
 PART NO. 36200

Use Part Number 276140 (Honda Engine)
 for pump assembly 362000

xx

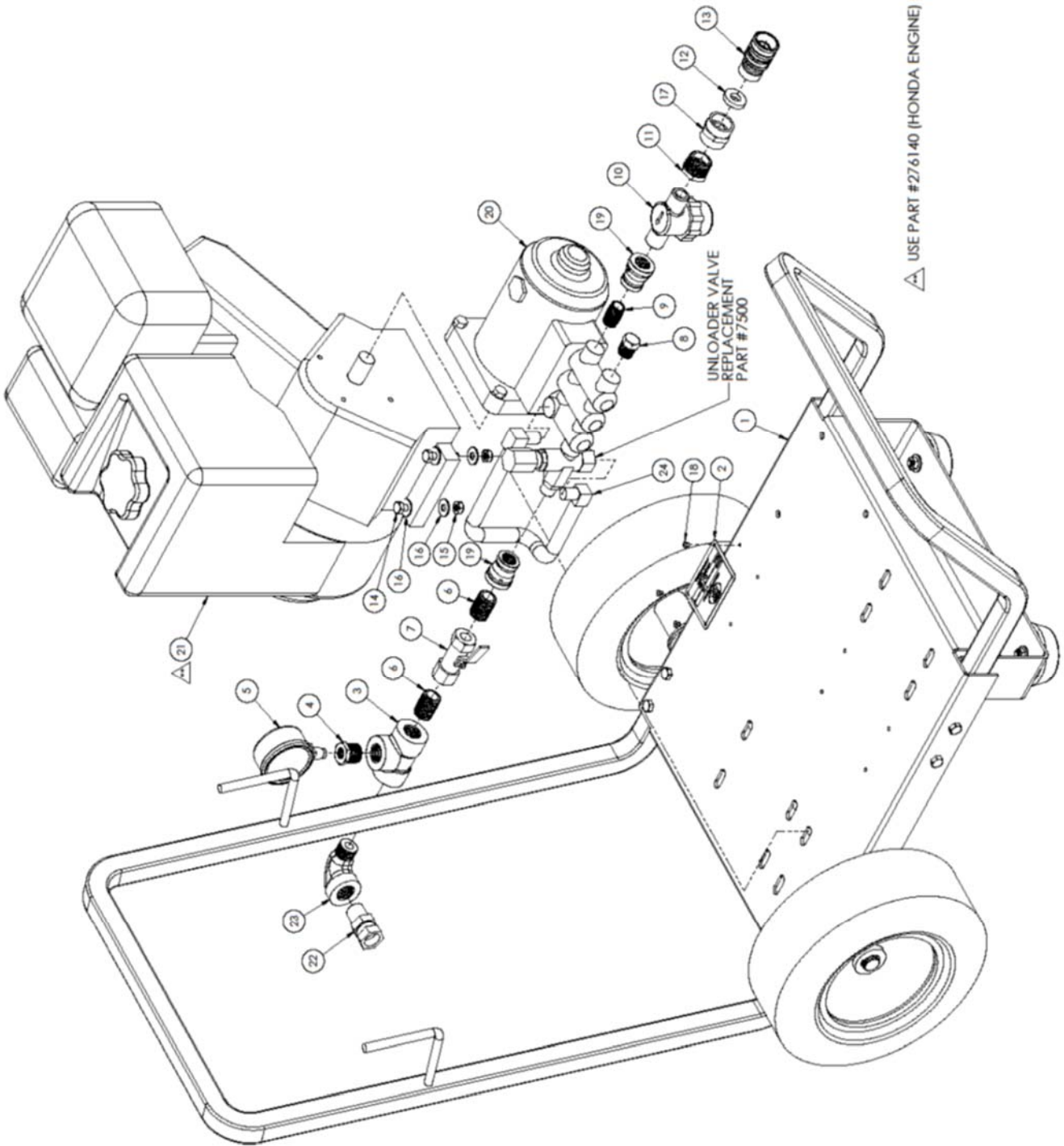
36200 Hydrostatic Test Pump			
Item	Part No	Description	Qty
1	220874	NAME PLATE	1
2	275667	1/2" 2000LB FS SCRD TEE	1
3	275670	1/2 X 1/4 FS SCRD FX BUSH	1
4	275676	GAUGE - 2000PSI	1
5	275669	1/2 X 1-1/2 XH PIPE NIPPLE	2
6	276744	1/2" VALVE	1
7	275768	3/8" HEX HEAD PLUG	1
8	275866	3/8" CLOSE STEEL NIPPLE	1
9	276420	STRAINER ASSEMBLY	1
10	275647	3/4" NPT X 1/2" NPT BUSHING	1
11	275941	HOSE WASHER	1
12	276099	3/4" HOSE QUICK DISCONNECT	1
13	275638	5/16" X 1-1/2" HEX HEAD CAP SCREW	4
14	275857	5/16-18 HEX NYLON INSERT LOCKNUT	8
15	275685	5/16" FLAT WASHER	12
16	275874	3/4" FH X 3/4" FP ADAPTER	1
17	275543	POP RIVET, STAR 4-2AAD	4
18	275668	1/2" NPT TO 3/8"NPT REDUCER CPLG	2
19	275779	TRIPLEX PLUNGER PUMP	1
20	275684	6.5HP BRIGGS & STRATTON ENGINE	1
	276140	5.5 HONDA ENGINE	1
21	275689	1.2" NPT X 1/2 SWIVEL ADAPTER	1
22	275915	BYPASS HOSE	1
23	276269	LARGE ROLL CAGE	1
24	700942	BASE PLATE	1
25	275639	5/16-18 X 1-3/4" HHCS	4
26	276443	RUBBER FOOT	4
27	220577	HIGH PRESSURE HOSE ** NOT SHOWN **	1
28	277181	WARNING LABEL ** NOT SHOWN **	1
29	34550	SUCTION HOSE ASSEMBLY **NOT SHOWN**	1



⚠ USE PART #276140 (HONDA ENGINE) FOR PUMP ASSEMBLY #462000



46200 Test Pump

46200 Hydrostatic Test Pump			
ITEM NO	PART NUMBER	DESCRIPTION	QTY
1	700136	PUMP CART	1
2	220874	NAME PLATE	1
3	275667	1/2" 2000LB FS SCRD TEE	1
4	275670	1/2 x 1/4 FS SCRD HX BUSH	1
5	275676	GAUGE-2000 PSI	1
6	275669	1/2 x 1-1/2 CLOSE PIPE NIPPLE	2
7	276744	1/2" VALVE	1
8	275768	3/8" HEX HEAD PLUG	1
9	275866	3/8 CLOSE STEEL NIPPLE	1
10	276420	STRAINER ASSEMBLY	1
11	275647	3/4" NPT x 1/2" NPT BUSHING	1
12	275941	HOSE WASHER	1
13	276099	3/4" HOSE QUICK DISCONNECT	1
14	275638	5/16-18 x 1 1/2" HEX HEAD CAP SCREW	4
15	275857	5/16-18 HEX NYLON INSERT LOCKNUTS	4
16	275685	5/16" FLAT WASHER	8
17	275874	3/4" FH x 3/4" FP ADAPTER	1
18	275543	POP RIVET, STAR 4-2AAD	4
19	275668	1/2"NPT TO 3/8" NPT REDUCER CPLG	2
20	275779	TRIPLEX PLUNGER PUMP	1
21	275684	6.5 HP BRIGGS & STRATTON ENGINE	1
	276140	5.5HP Honda Engine	1
22	275689	1/2 NPT x 1/2 SWIVEL ADAPTER	1
23	275666	1/2" FS SCRD STREET ELL	1
24	275915	BYPASS HOSE	1
25	277181	WARNING TAG ***NOT SHOWN***	1
26	220577	PRESSURE HOSE ***NOT SHOWN***	1
27	34550	SUCTION HOSE ***NOT SHOWN***	1



Wheeler Rex ▪ 3744 Jefferson Road ▪ Ashtabula, Ohio 44005
Tel: 800-321-7950 or 440-998-2788 ▪ Fax: 440-992-2925
wheeler@wheelerrex.com ▪ www.wheelerrex.com